

— WRITING SAMPLE —

Stephen X. Arthur, technical writer

*Note:* substantive, style, and copy editing only

www.sxa-portfolio.com

Copyright © 2004 Adwel International, Toronto

Chapter

1

# Introduction

## Overview

---

**COPA PDA ON-LINE** is a continuous, on-line monitoring system that automatically measures partial discharge (PD) activity from rotating machines—specifically, the stator windings of generators and motors.

Partial discharge refers to small voltage losses that occur when the critical field strength in a high-voltage insulation system is exceeded. Ongoing partial discharges can cause a degradation of the insulating material over time and failure of the rotating machine.

The COPA system performs data acquisition, noise rejection, and data processing. By monitoring PD activity, stator deterioration can be detected. If not corrected, this can lead to catastrophic failure of a machine.

This manual describes how to operate and maintain the COPA system efficiently and safely. The Appendix contains installation and technical specifications for the equipment, as well as a glossary of electrical terms.

## Features

---

### ***System Components***

The COPA PDA ON-LINE system consists of:

- Partial Discharge Data Acquisition Unit (PDDAU)
- Analog Data Acquisition Unit (ADAU)
- a personal computer (PC) with Windows-XP Professional
- a software suite with:
  - COPA PD Watch (handles system setup and operation)
  - COPA PD Export
  - COPA PD Analysis
  - COPA PD Trending

### ***System Operation***

- Automatically acquires partial discharge (PD) pulse data from permanently mounted couplers on a stator winding of a generator or motor—i.e, a rotating machine. (Couplers may be pre-existing or newly installed, and may operate as capacitive or inductive.)
- Monitors multiple rotating machines to identify problems and reduce the risk of forced outages.
- Can be used on rotating machines connected to 25 Hz, 50 Hz, or 60 Hz power systems.
- Eliminates noise external to the rotating machine.

### ***System Connections***

- Accepts inputs from 3 to 24 couplers per rotating machine.

- Can be connected to capacitive couplers of different values or a variety of high-frequency current transformers.
- Connected to a central PC in a control room through a LAN (local area network).
- Up to 16 ADAU's may be networked together to collect analog data from 96 rotating machines in one PC.

### ***Data Collection and Analysis***

- Takes readings upon user request, when PD levels exceed specified limits, or within a scheduled time period.
- Identifies the nature and cause of the readings by detecting stator deterioration factors, such as wedge and winding looseness, end winding discharge, internal voids, and delaminations.
- Alerts user when predefined PD thresholds are exceeded.
- Determines the number, amplitude, and polarity of the PD pulses. Classifies PD data by magnitude and phase angle.
- Automatically collects, displays, and updates PD data and related operating conditions together on a central PC screen.
- Provides 3D phase-resolved maps showing where the PD is occurring on the AC cycle (relative to the voltage sine wave). This eases diagnosis of the problem and confirms noise rejection.
- Displays trends in PD activity over time via user-selected graphs, scales, and time periods. Multiple graphs can be compared to show increases in PD activity. This allows

assessment of stator insulation deterioration over time, and preventive maintenance on the stator.

- COPA data can be easily exported to EXCEL® and other major spreadsheet programs for further analysis and report generation.
- COPA PD-Analysis software is compatible with portable PDA-Standard (formerly PDA-H™) and PDA Premium results.

## **COPA Hardware**

---

### ***PD Data Acquisition Unit (PDDAU)***

The PDDAU continuously collects partial discharge (PD) activities on a connected rotating machine. The PDDAU can obtain input from between 3 and 24 permanently-installed couplers on the machine.

See Figure 2 at the end of this chapter for a diagram showing how the PDDAU is connected to the rotating machine.

The PDDAU provides Qmax values and other measurement data in three ways:

- by reaching or exceeding a user-defined Qmax threshold
- at user-prescribed time intervals
- upon manual request from the central PC (CPC)

The CPC takes the PD data and synchronizes it with the analog values collected by the ADAU (see below).

Trending data is collected at user-prescribed date intervals.

The main switch on the front panel turns the PDDAU on and off.

## ***Analog Data Acquisition Unit (ADAU)***

The ADAU collects these analog values from rotating machines:

- active load
- reactive load
- winding temperature
- hydrogen pressure or humidity

See Figure 3 at the end of this chapter for a block diagram showing the ADAU connections to the CPC.

The ADAU accepts the analog values as passive input, 4–20 mA, with an input impedance of 200  $\Omega$ . The system takes the highest absolute value of positive and negative  $Q_{max}$  of all couplers on one phase and converts it into an active current output of 4–20 mA, proportional to the  $Q_{max}$  value for each phase. The  $Q_{max}$  value can range from 0–6400 mV.

ADAU uses NO and NC relay contacts to indicate the alert status (the contacts can be wired to the user's annunciator panel.) Each phase has one NO/NC relay output, and each coupler has its own alert threshold level. The relays are activated when the specified alert thresholds are reached.

If a threshold is reached, COPA saves the data from the alert activities, along with current PD activities. The front panel of the ADAU also displays alert activities by illuminating the corresponding red LED. The LED turns off when PD activity drops or when the user increases the threshold level. It cannot be reset manually.

The central PC (CPC) collects the analog data, sets current outputs, and sets the alert relays.

One COPA system accepts up to 16 ADAU's. Each ADAU accepts up to 6 boards, and each board covers one machine with input/output and relay status.

The main switch on the front panel turns the ADAU on and off.

### ***Central PC (CPC)***

All system setup is done through the CPC, which is connected through a local area network (LAN). The LAN may be an independent network or part of an existing network.

The CPC displays a real-time bar graph with the Qmax value, analog values, and the status of the ADAU and PDDAU.

## **COPA Software Suite**

---

COPA consists of four different software applications that are responsible for interface, control, and communication, as well as data analysis.

### ***COPA PD-Watch***

All system setup and operation is done through COPA PD-Watch software. This software runs continuously and carries out the following functions:

- continuously monitors partial discharge activity and machine operating values
- displays bar graphs proportional to the Qmax value, showing a positive and negative value for each coupler
- saves (on request) the trending values and measurements in the database

### ***COPA PD-Analysis***

This application displays the measured data in different graphs. It allows analysis of PD activities and comparisons between any number of graphs at the same time. The graphs can display the values of Qmax and NQN pulses per second, and phase distribution of the pulses.

### ***COPA PD-Trending***

COPA PD-Trending is helpful tool for analyzing the values of Qmax and NQN over a long time period. Qmax and NQN can be displayed together on two separate graphs. The selection of couplers, colors, time period, and scale is simple and straightforward.

### ***COPA PD-Export***

This application converts data saved in the database into COPA PD-Analysis format (file extensions: \*.pan and \*.msr).

## **Installation**

---

Figure 1 on the next page shows a typical installation of the COPA PD-ONLINE system.

ADWEL International Ltd. will connect and install the COPA system with permanently-installed couplers. We will also help customers install and connect the Analog Data Acquisition Unit (ADAU), and install and set up the software.

For more information on installation specifications for all components, see *Appendix 1*.

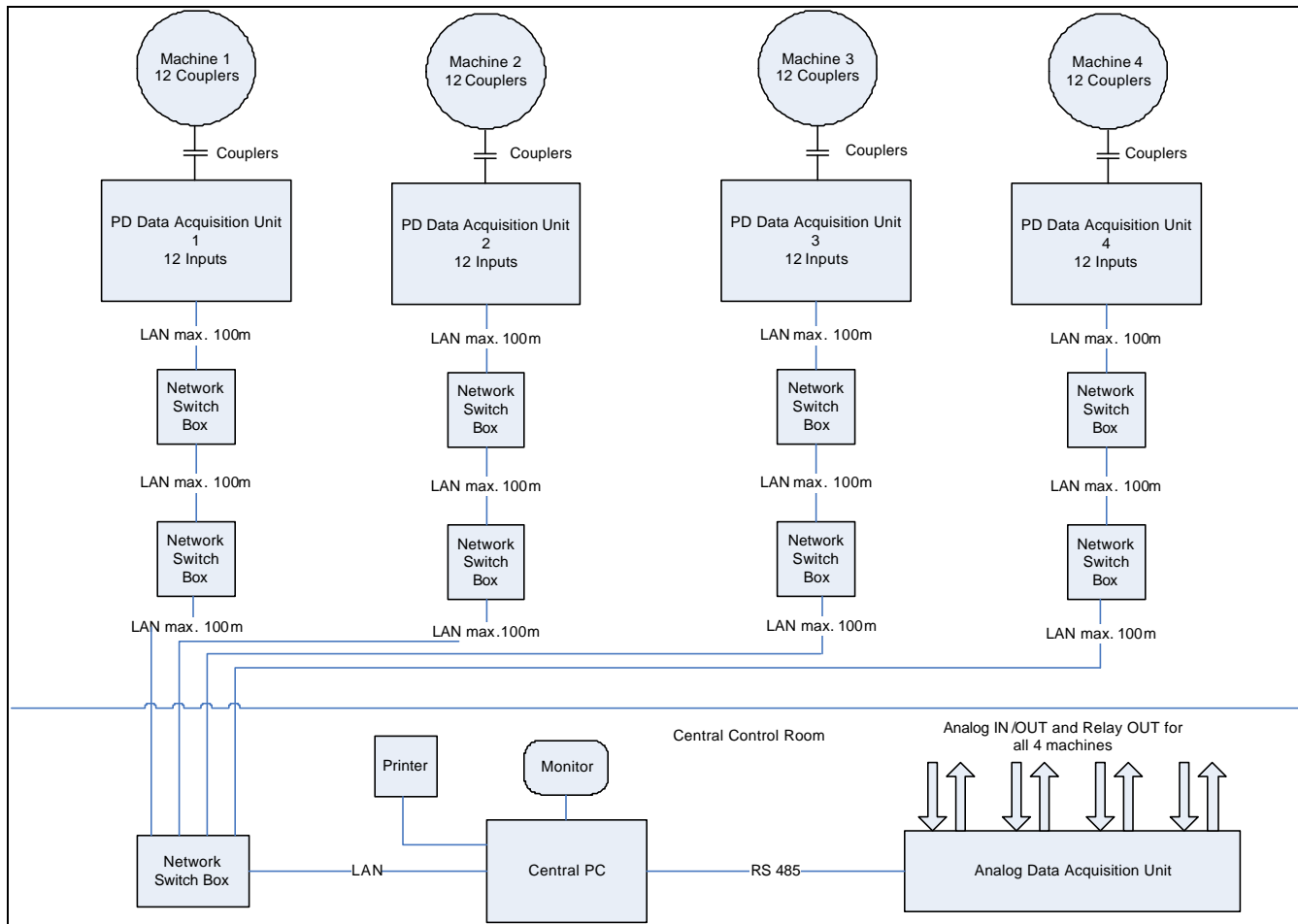

**Figure 1: Typical Set-up for the COPA PD-ONLINE System.** In this example, the COPA system is installed on 4 rotating machines with 12 couplers each. The rotating machines are connected through couplers to the PDDAU, which in turn is connected to the LAN via a network switch box to the central PC (CPC). The CPC runs the COPA software suite and has an attached monitor and optional printer. The CPC exchanges data with the ADAU through an RS485 communication link. The ADAU has analog in/out (4–20mA) relay contacts (NO/NC for alert indication) and LED alert indicators. Both the CPC and ADAU are located in the central control room.

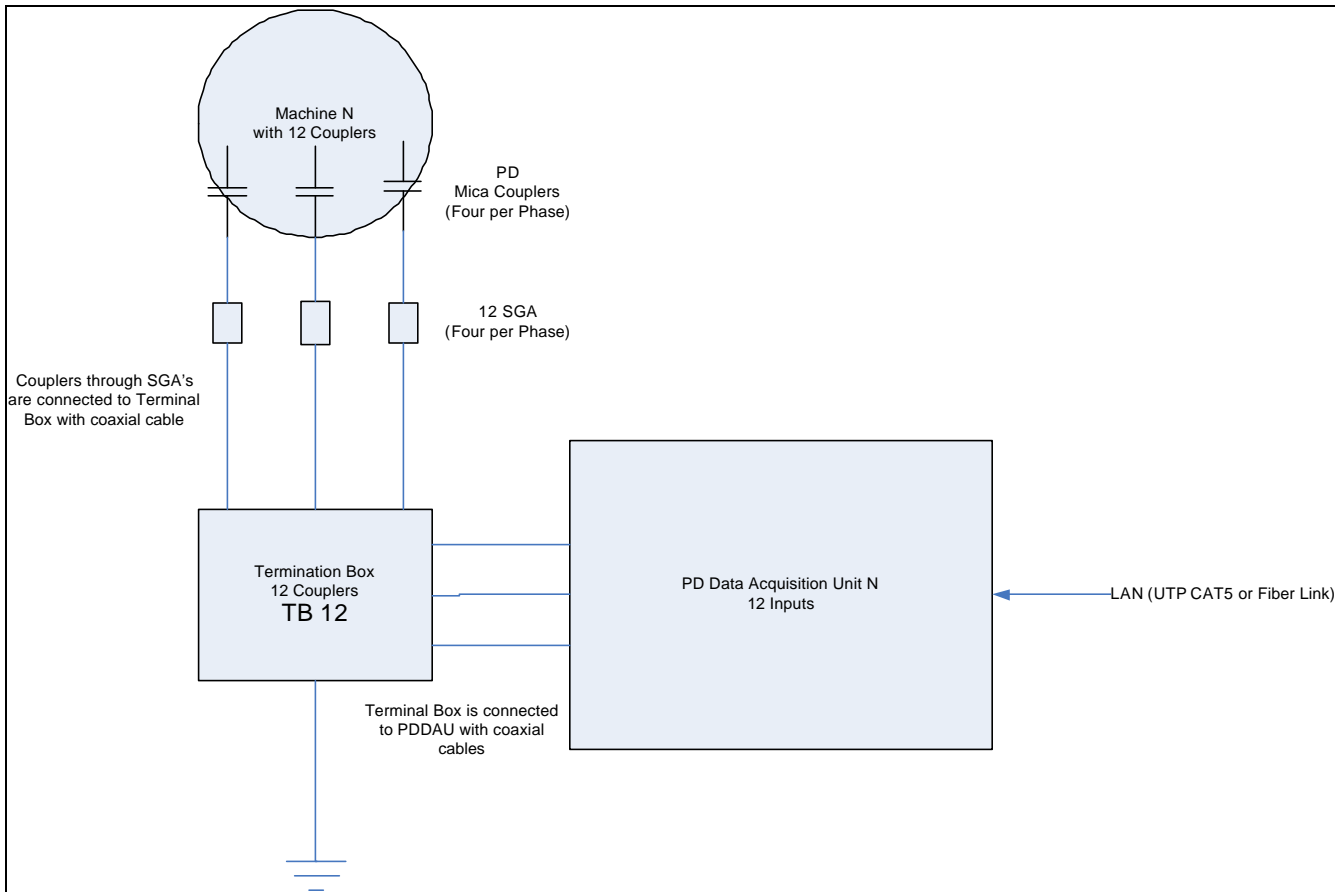

**Figure 2: PDDAU Connection to Rotating Machine.** The rotating machine is connected through the PD couplers and SGA's (shield grounding assembly) to a termination box. The PDDAU receives input from the termination box and communicates with the LAN (local area network).

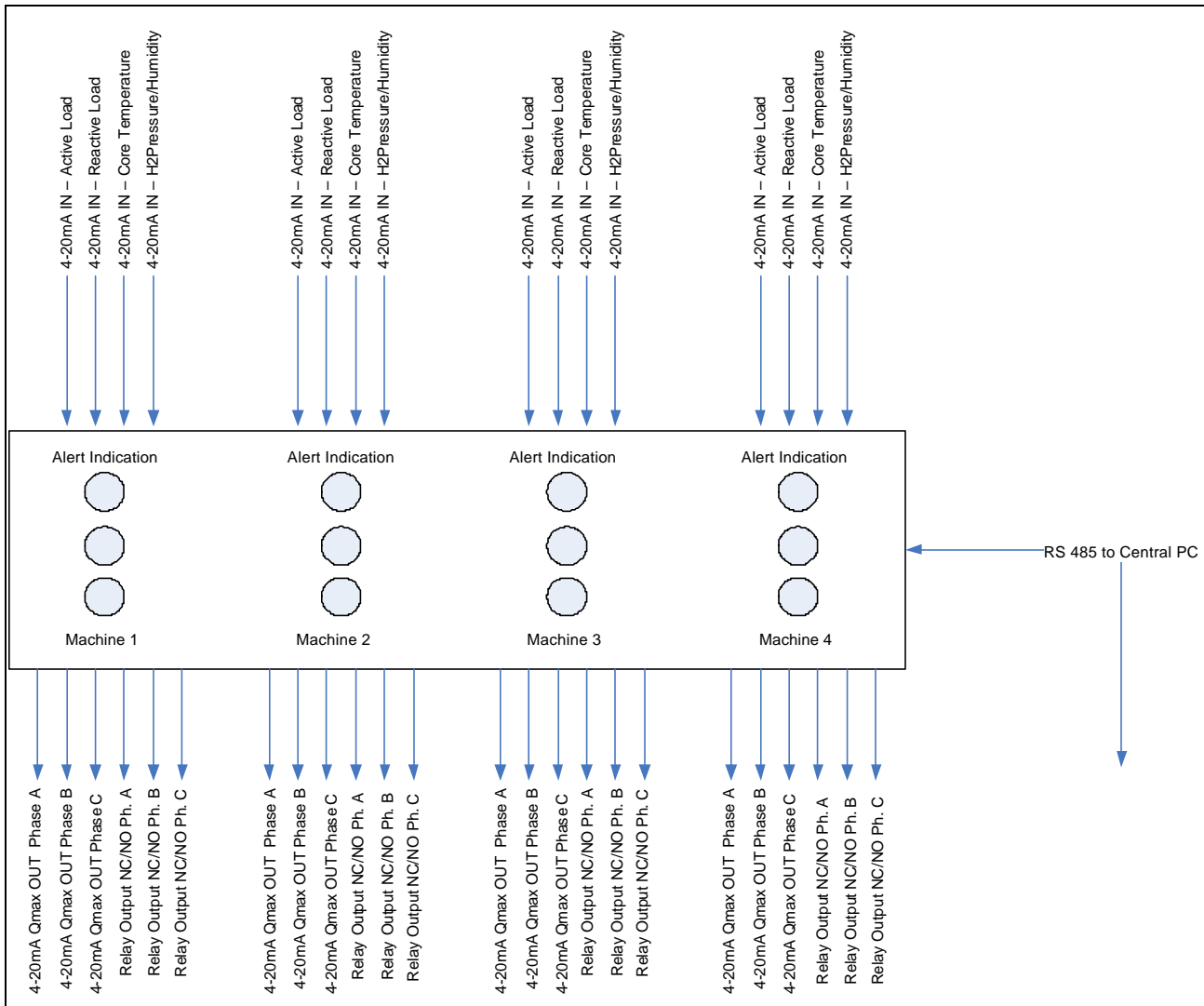

**Figure 3: ADAU Block Diagram Showing Connections to CPC.** The ADAU receives analog inputs (4–20 mA) for active load, reactive load, core temperature, and hydrogen pressure or humidity. The ADAU converts the values to an active current output of 4–20 mA, proportional to the Qmax for each phase. The ADAU uses NO/NC relay contacts for remote alert indications.